

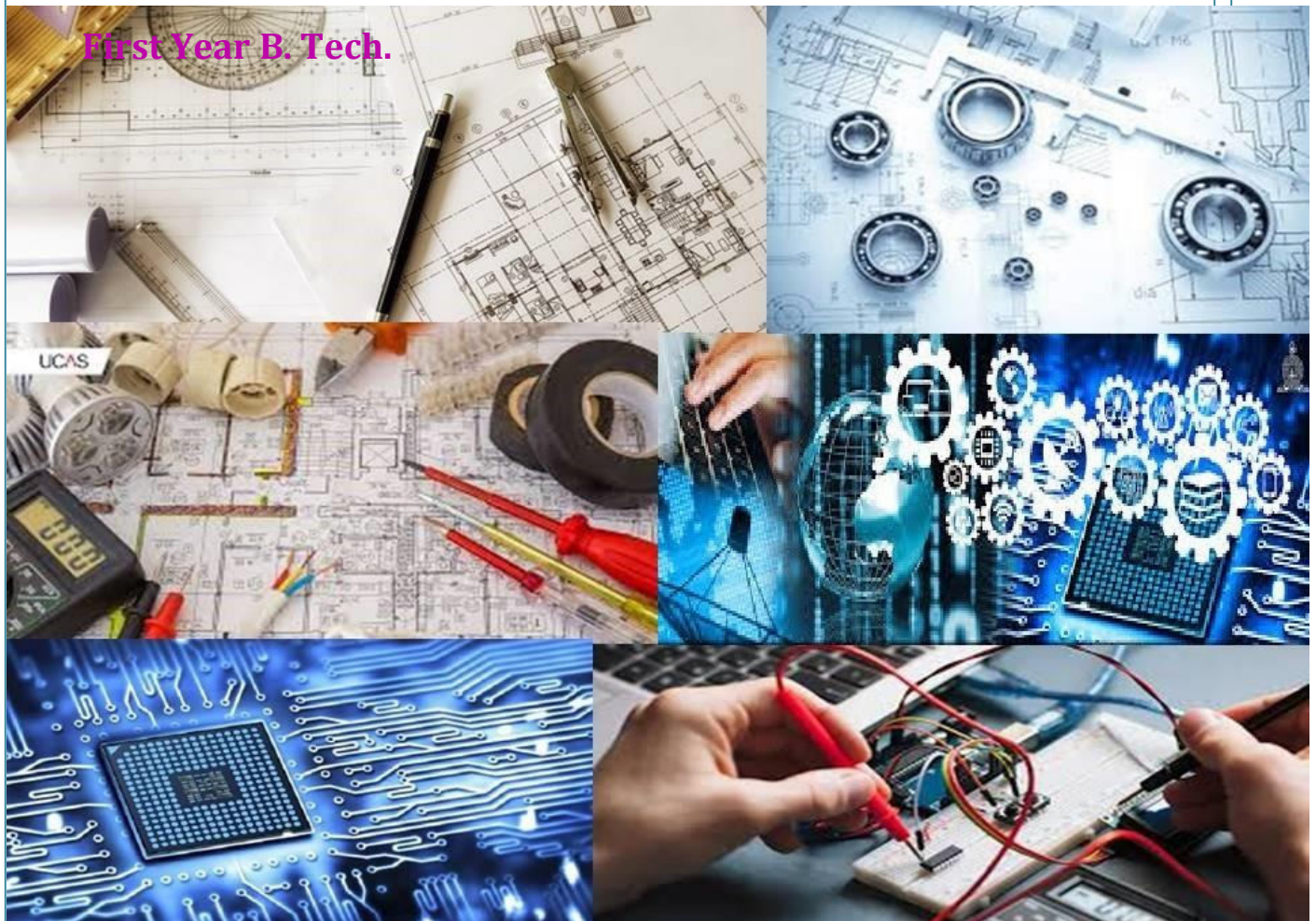

Dr. V.P.S.S.M's
Padmabhooshan
Vasanttraodada Patil Institute of
Technology, Budhgaon (Sangli)

Student Information Manual (SIM) 2023-24 SEM-II





Dr. V. P. Shetkari Shikshan Mandal's
Padmabhooshan Vasantraodada Patil
Institute of Technology, Budhgaon- 416304
STUDENT'S INFORMATION MANUAL
(Academic Year: 2023-24)
Semester-II
Teaching and
Evaluation Scheme
for
First Year B. Tech.
Group A



Department of First Year
Engineering



Department of First Year Engineering

The Department of **First Year Engineering** is established in the year 1983 with the establishment of institute. The department has a good intermingle of experienced and young faculty which works as a team to strengthen the department.

VISION OF DEPARTMENT

To orient, educate and develop students in applying fundamentals of sciences to Engineering leading to smooth and successful transfer to an undergraduate degree engineering program.

MISSION OF DEPARTMENT

1. To create an environment where students can ascertain that career in engineering matches their interests and abilities.
2. To impart strong fundamental and technical knowledge in the basic science subjects to enable them to prepare themselves for successful career.
3. To inculcate habit of innovation and entrepreneurship.

GOALS

1. To achieve 100 % results in academics.
2. To inculcate competitive attitude by supporting and guiding them to participate in national competition.
3. To develop basic skills and human values required to undertake further studies.



STRUCTURE C F FIRST YEAR ENGINEERING

(With effective from Academic Year 2023-24)

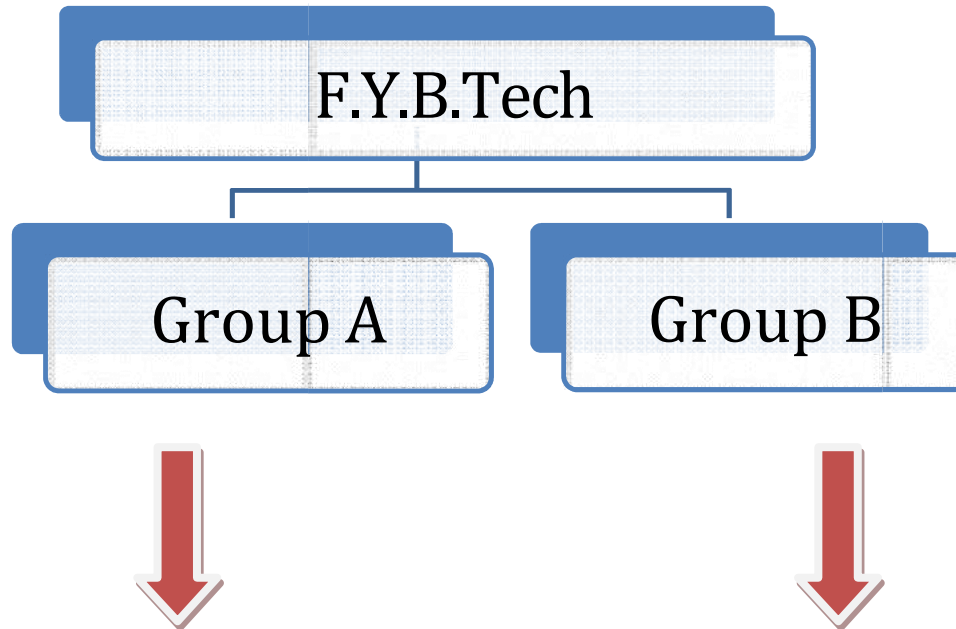

1. Computer Science and Engineering
2. Computer Science and Engineering (AI&DS)
3. Electronics and Computer Science Engineering
4. Instrumentation and control Engineering

1. Chemical Engineering
2. Civil Engineering
3. Mechanical Engineering
4. Mechatronics Engineering
5. Electronics & Telecommunication Engg.
6. Electrical and Computer Engineering

**INDEX**

Sr. No.	Content	Page No.
<u>DEPARTMENTAL INFORMATION</u>		
1	Role of Students	6
2	Laboratory Instructions	7
3	Teaching and Evaluation Scheme	8
4	Course Coordinators and Course Teachers	9
5	Class Teacher	10
6	Academic Calendar	11
7	Time Table	12-14
<u>DEPARTMENTAL ACTIVITIES</u>		
11	Mentoring Activity	15
12	Counseling Activity	15
13	Class Teacher Activity	16
14	Remedial Lectures, Test Series (Unit Test, Open Book Test, Prelim), Co/Extra Curricular Activities	16
15	Anti-Ragging Activity	17
16	Library, Gymkhana, NSS, Hostel	18
17	Training and Placement Office	19
<u>SUBJECT INFORMATION</u>		
18	Engineering Mathematics-I	20
19	Engineering Physics	24
20	Engineering Graphics	29
21	Communication Skills	34
22	Energy and Environment Engineering	38
23	Basic Civil and Mechanical Engineering	42
24	Credit System and Mode of evaluation	44



THE ROLE OF STUDENTS

As our society/ nation grows and becomes technologically more strong/ complex, it needs more trained Engineers. Students can contribute to this professional growth by playing an effective and disciplined role during their studies.

Responsibilities:

1. 100% Attendance and active participation in all academic activities.
2. Self-discipline and good relations with other students, teaching and support staff.
3. Positive attitude, motivation and technical thinking.
4. Participation in Co-Curricular and Extra-Curricular activities.
5. Carrying Identity Card and following the College Dress Code.
6. Pursuing all-round personality development with good generic skills.
7. Following the Code-of-Conduct laid down by the Department, Institute and University.

Code-of-Conduct: Students Shall

- Attend all Lecture's and Practical's in time.
- Not take common off, Leave without permission.
- Roaming in the campus premises during academic work or disturbing the campus activities through shouting/ misconduct is strictly not allowed.
- Use of personal unauthorized electronic gadgets without permission in department premises is not allowed.
- Attendance should be 100 % otherwise you will be ineligible for Exams.
- Not include themselves into any form of violence, ragging, use of tobacco, alcohol or drugs in campus.
- Let us all- Society, parents, teachers and students join hands and put our best efforts to imbibe the above mentioned behavior in our students.
- Maintain silence in class rooms
- Don't write anything on seating bench and walls of classroom
- Keep their mobiles switched off in classroom.
- Your reason of absence should be timely informed to your class teacher with written application.
- Help to conserve energy, Switch off fans and tubes before leaving the classroom.
- Keep the Classrooms clean.



Laboratory Instructions

Laboratory Instructions

- ❖ Read all the instructions carefully.
- ❖ Always keep silence in the laboratory.
- ❖ Keep your mobiles switched off in the laboratory.
- ❖ Always wear an apron before starting your laboratory work.
- ❖ Always carrying Identity Card and following the College Dress Code.
- ❖ Handle hazardous chemicals and concentrated chemicals carefully.
- ❖ Handle all electronics Devices /Equipment's carefully.
- ❖ Follow safety procedures and avoid damage to self and equipment.
- ❖ Be aware with what you are doing and why you are doing it.
- ❖ Except in emergency, don't run in laboratory.
- ❖ Inform the lab assistant or lab in-charge when any fault arises during the performance of an experiment.
- ❖ Report any not working equipment to the lab instructor; don't open/ remove the cover/ attempt to repair any equipment.
- ❖ Keep the working table always neat and clean.
- ❖ Be aware with the place of fire extinguisher and the method of using it.
- ❖ If any accident occurs, report it at once to the person concerned (Lab In charge).
- ❖ Use laboratory first aid box for any minor accident.
- ❖ Help to conserve energy, Switch off the equipment's tubes and fans before leaving the laboratory.
- ❖ Do not move the instruments from one laboratory to another, without permission.

**First Year B. Tech. Teaching and Evaluation Scheme****Group - A Semester- II**

**(Computer Science and Engineering / Computer Science and Engineering (AI&DS)/
Electronics and Computer Science Engineering, Instrumentation and control
Engineering)**

Sr. No.	Course Code	Name of Course	Teaching Scheme			Evaluation Scheme				Credit
			L	T	P	CA	MSE	ESE	Total	
1	BTBS201	Engineering Mathematics-II	3	1	-	20	20	60	100	4
2	BTBS202	Engineering Physics	3	1	-	20	20	60	100	4
3	BTES203	Engineering Graphics	2	-	-	20	20	60	100	2
4	BTH2104	Communication Skills	2	-	-	20	20	60	100	2
5	BTE2105	Energy and Environment Engineering	2	-	-	20	20	60	100	2
6	BTES206	Basic Civil and Mechanical Engineering	2	-	-	50	-	-	50	Audit
7	BTBS207L	Engineering Physics Laboratory	-	-	2	60	-	40	100	1
8	BTES208L	Engineering Graphics Laboratory	-	-	4	60	-	40	100	2
10	BTHM209L	Communication Skills Laboratory	-	-	2	60	-	40	100	1
Total			14	2	8	330	100	420	850	18

**COURSE CO-ORDINATOR**

Sr. No.	Course	Corse Code	Course Coordinator	Emailid	ContactNo.
1	Engineering Mathematics-II	BS201	Mrs. S. P. Mandale	spmadaled.ge@pvpitsangli.edu.in	9172035381
2	Engineering Physics	BS202	Dr. S. L. Patil	slpatil.ge@pvpitsangli.edu.in	9423269875
3	Engineering Graphics	BE203	Mr. S. B. Khandagale	sbkhandagale@pvpitsangli.edu.in	7798934522
4	Communication Skill	HM204	Mr.S. E. Narwade	senarwade.ge@pvpitsangli.edu.in	9527057048
5	Energy and Environmental Engineering	ES205	Mr. P. P. Shinde	ppshinde@pvpitsangli.edu.in	8600732033
6	Basic Civil and Mechanical Engineering	ES206	Mr. M. S. Kakmare	mskakamare.civil@pvpitsangli.edu.in	9860681768

NOTE: Any query or suggestion in above subject should contact with respective subject Coordinator

CLASS TEACHERS

Sr. No.	Class/ Div	Class Teachers	Department	Email id	Contact No.
01	I	Ms. P. B. Patil	Chemistry	patilprajakta9102@gmail.com	9518599062
02	II	Dr. S. L. Patil	Physics	slpatil.ge@pvpitsangli.edu.in	9423269875
03	III	Mrs. S. P. Mandale	Mathematics	spm.ge@pvpitsangli.edu.in	9172035381
04	IV	Ms. A. K. Patil	Mathematics	ashwinipatil10599@gmail.com	9623653978
05	V	Mrs. D. A. Lavate	Chemistry	dalavate.ge@pvpitsangli.edu.in	8788009691
06	VI	Mr. A. K. Chavan	Communication Skill	chavanak01@gmail.com	9834750779
07	VII	Ms. G. G. Chinde	Physics	chindegandhali@gmail.com	9970371111

**COURSE TEACHERS****SEM-II**

Division/Class Course	II	IV	VI	VII
Engineering Maths-II	Dr. A. A. Patil	Ms. A. K Patil	Mrs. S. P. Mandale	Mr. R. U. Yadav
Communication Skills	Mr. S. E. Narwade	Mr. S. E. Narwade	Mr.A.K.Chavan	Mr.A. K. Chavan
Engineering Physics	Dr.S.L.Patil	Mr. A. A. Shaikh	Mr. A. A. Shaikh	Ms. G. G. Chinde
Engineering Graphics	Mrs. S. P. Mane	Mr. S. B. Khandagale	Mrs. A. P. Lad	Mr.C. D. Patil
Basic Civil and Mechanical Engg.	Mr. M. S. Kakmare	Mr. M. S. Kakmare	Mr. M. S. Kakmare	Mr. M. S. Kakmare
Energy and Environment Engg.	Mr. P. V. Kadam	Mr.P. P. Shinde	Mr.P. P. Shinde	Mr. P. V. Kadam



ACADEMIC CALENDAR 2023-24 SEM-II



Dr. Vasantrodada Patil Shetkari Shikshan Mandal's
Padmabhooshan Vasantrodada Patil Institute of Technology,
Budhgaon Sangli – 416 304

Academic Calendar (2023-24) Semester II**February 2024 - Academic Days: 22**

M	T	W	T	F	S	S
			1	2	3	4
5	6	7	8	9	10	11
12	13	14	15	16	17	18
19	20	21	22	23	24	25
26	27	28	29			

Commencement of Term	1 st Feb 2024
Chhatrapati Shivaji Maharaj Jayanti	19 th Feb 2024
Science Day	28 th Feb 2024
List of students not reported	29 th Feb 2024
1st Defaulter List	29 th Feb 2024

March 2024 - Academic Days: 21

M	T	W	T	F	S	S
				1	2	3
4	5	6	7	8	9	10
11	12	13	14	15	16	17
18	19	20	21	22	23	24
25	26	27	28	29	30	31

Late Vasantdada Punyatithi	1 st Mar 2024
Mahashivratri and Women's Day	8 th Mar 2024
CA 1 Evaluation	6 th -9 th Mar 2024
Dhulivandan	25 th Mar 2024
Good Friday	29 th Mar 2024
2nd Defaulter List	31 st Mar 2024

April 2024 - Academic Days: 21

M	T	W	T	F	S	S
1	2	3	4	5	6	7
8	9	10	11	12	13	14
15	16	17	18	19	20	21
22	23	24	25	26	27	28
29	30					

Gudi Padwa	9 th Apr 2024
Ramzan Id	11 th Apr 2024
Dr. Babasaheb Ambedkar Jayanti	14 th Apr 2024
Shri Ram Navami	17 th Apr 2024
Mahavir Jayanti	21 st Apr 2024
Mid Semester Exam	18 th – 19 th Apr 2024
Display of Mid Sem Marks	25 th – 27 th Apr 2024
Parents Meeting	27 th April 2024
Annual Social Gathering	
3rd Defaulter List	30 th Apr 2024

May 2023 - Academic Days: 18

M	T	W	T	F	S	S
		1	2	3	4	5
6	7	8	9	10	11	12
13	14	15	16	17	18	19
20	21	22	23	24	25	26
27	28	29	30	31		

Maharashtra Day	1 st May 2024
CA 2 Evaluation	20 th -22 nd May 2024
Buddha Pournima	23 rd May 2024
Sports Week	
End of Classes	25 th May 2024
Final Defaulter List	25 th May 2024
Practical Examination	27 th – 31 st May 2024

June 2024 - Academic Days: - NIL

M	T	W	T	F	S	S
					1	2
3	4	5	6	7	8	9
10	11	12	13	14	15	16
17	18	19	20	21	22	23
24	25	26	27	28	29	30

End Semester & Supplementary Exam	3 rd – 14 th June 2024
Bakri Id	17 th June 2024

Dr..K.K. Pandeyaji
Dean Academics

Dr. B.S.Patil
Principal

Academic Activity
 Co-curricular activity
 Holidays
 Events
 Academic Compliance



Dr. Vasatraodada Patil Shtekari Shikshan Mandal's
Padmabhooshan Vasatraodada Patil Institute Of Technology,
Budhgaon. (Sangli)
FIRST YEAR ENGINEERING DEPARTMENT (F. Y. B. Tech)
TIMETABLE 2023-24 SEM-II

With Effect From 01/02/2024

TIME TABLE



Dr. Vasatraodada Patil Shtekari Shikshan Mandal's
Padmabhooshan Vasatraodada Patil Institute of Technology, Sangli
FIRST YEAR ENGINEERING DEPARTMENT (F. Y. B. Tech)
TIMETABLE 2023-24 SEM-II

With Effect From 01/02/2024

Class: FE-II Branch: - Computer Science Engineering PHYSICS Group CL-05

Sr. No.	TIME IN HRS	MONDAY	TUESDAY	WEDNESDAY	THURSDAY	FRIDAY	SATURDAY
1	10:00 TO 11:00	ES206- MSK	BS201- AAP	BS201- AAP	B1- ES208L B2- ES210S	B1- ES208L B2- HM209L	LVH @- IITST-
2	11:00 TO 12:00	BS201- AAP	BS202- SLP	BS202- SLP	B3- BS207L	B3-202(T)/201(T)	
	12:00 TO 12.45	LONG RECESS					
3	12.45 TO 13:45	HM204- SEN	ES205-SSG	B1- ES210S	B1- HM209L	BS202- SLP	
4	13:45 TO 14:45	ES203- SPM	HM204- SEN	B2- BS207L B3- ES208L	B2- 202(T)/201(T) B3- ES208L	ES205- SSG	
	14:45 TO 15:00	SHORT RECESS					
5	15:00 TO 16:00	B1- BS207L B2- ES208L	B1- 202(T)/201(T) B2- ES208L	# TPO Session / Guest Lec. / M-M / Counselor Int.	ES203- SPM	*BS201- AAP	
6	16:00 TO 17:00	B3- HM209L	B3- ES210S		ES206- SPM	*ES203- SPM	

AAP- /A A Patil SLP- S L Patil SEN- S E Narwade SPM- /S P Mane SSG- S S Gunjate MSK- M S Kakamare
M-M / Counselor Int. Mentee –Mentor or Counselor Interaction *-Extra (T)-Tutorial # - Alternate LVH-Library Visit Hour @- IITST-IIT Spoken Tutorial

Sr. No.	Course Code	Name of the Course	Sr. No.	Course Code	Name of the Course	Sr. No.	Course Code	Name of the Course
1	BS201	Engineering Mathematics-II	4	HM204	Communication Skills	7	BS207L	Engineering Physics Laboratory
2	BS202	Engineering Physics	5	ES205	Energy and Environment Engineering	8	ES208L	Engineering Graphics Laboratory
3	ES203	Engineering Graphics	6	ES206	Basic Civil and Mechanical Engineering	9	HM209L	Communication Skills Lab
						10	ES210S	Seminar

(Dr. Sanjay L. Patil)
Time-Table Coordinator
(F. Y. B. Tech.)

(Dr. Anushka A. Patil)
HOD
(F. Y. B. Tech.)

(Dr. K. K. Pandiyaji)
Academic Dean

(Dr. B. S. Patil)
I/C Principal



Dr. Vasatraodada Patil Shetkari Shikshan Mandal's

Padmabhooshan Vasatraodada Patil Institute of Technology, Sangli
FIRST YEAR ENGINEERING DEPARTMENT (F. Y. B. Tech)
TIMETABLE 2023-24 SEM-II

With Effect
From
01/02/2024

Class: FE-IV Branch: Computer Science Engineering PHYSICS Group CL-06

Sr. No.	TIME IN HRS	MONDAY	TUESDAY	WEDNESDAY	THURSDAY	FRIDAY	SATURDAY
1	10:00 TO 11:00	BS201- AKP	BS201- AKP	D1- BS207L D2- ES208L	ES203- SBK	D1- ES208L D2- ES210S	LVH
2	11:00 TO 12:00	BS202- AAS	HM204- SEN	D3- HM209L	BS202- AAS	D3- BS207L	@- IITST-
	12:00 TO 12.45	LONG RECESS					
3	12.45 TO 13:45	D1- HM209L D2- 202(T)/201(T)	ES203- SBK	BS202- AAS	D1- ES210S D2- BS207L	ES206- SBK	
4	13:45 TO 14:45	D3- ES208L	ES205- PPS	BS201- AKP	D3- ES208L	HM204- SEN	
	14:45 TO 15:00	SHORT RECESS					
5	15:00 TO 16:00	ES205-PPS	D1- ES208L D2- HM209L	# TPO Session / Guest Lec. / M-M / Counselor Int.	*ES203- SBK	D1- 202(T)/201(T) D2- ES208L	
6	16:00 TO 17:00	ES206- MSK	D3-202(T)/201(T)		*BS201- AKP	D3- ES210S	

AKP- A K Patil AAS- A A Shaikh SBK- SB Khandagale SEN- S E Narwade PPS- P P Shinde MSK- M S Kakamare
 # M-M / Counselor Int. Mentee –Mentor or Counselor Interaction *-Extra (T)-Tutorial # - Alternate LVH-Library Visit Hour @- IITST-IIT Spoken Tutorial

Sr. No.	Course Code	Name of the Course	Sr. No.	Course Code	Name of the Course	Sr. No.	Course Code	Name of the Course
1	BS201	Engineering Mathematics-II	4	HM204	Communication Skills	7	BS207L	Engineering Physics Laboratory
2	BS202	Engineering Physics	5	ES205	Energy and Environment Engineering	8	ES208L	Engineering Graphics Laboratory
3	ES203	Engineering Graphics	6	ES206	Basic Civil and Mechanical Engineering	9	HM209L	Communication Skills Lab
						10	ES210S	Seminar

(Dr. Sanjay L. Patil)
Time-Table Coordinator
(F. Y. B. Tech.)

(Dr. Anushka A. Patil)
HOD
(F. Y. B. Tech.)

(Dr. K. K. Pandeyaji)
Academic Dean

(Dr. B. S. Patil)
I/C Principal



Dr. Vasanttraodada Patil Shetkari Shikshan Mandal's
Padmabhooshan Vasanttraodada Patil Institute of Technology, Sangli
FIRST YEAR ENGINEERING DEPARTMENT (F. Y. B. Tech)
TIMETABLE 2023-24 SEM-II

With Effect
 From
 01/02/2024

Class: FE-VI Branch: Electronics and Comp. Science Engg. (ECS) PHYSICS Group CL-07

Sr. No.	TIME IN HRS	MONDAY	TUESDAY	WEDNESDAY	THURSDAY	FRIDAY	SATURDAY
1	10:00 TO 11:00	ES203- APL	F1- ES208L	ES205- PPS	F1- ES208L	ES203- APL	LVH
2	11:00 TO 12:00	HM204- AKC	F2- ES210S	BS201- SPM	F2- HM209L	BS202- AAS	@- IITST
	12:00 TO 12.45	LONG		RECESS			
3	12.45 TO 13:45	F1- ES210S	BS202- AAS	F1-202(T)/201(T)	BS202- AAS	ES206- APL	
4	13:45 TO 14:45	F2- BS207L	ES206- MSK	F2- ES208L	BS201- SPM	HM204- AKC	
	14:45 TO 15:00	SHORT		RECESS			
5	15:00 TO 16:00	BS201- SPM	ES205- PPS	# TPO Session /	F1- HM209L	F1- BS207L	
6	16:00 TO 17:00	*ES203- APL	*BS201- SPM	Guest Lec. / M-M /	F2-202(T)/201(T)	F2- ES208L	
				Counselor Int.	F3- ES208L	F3- HM209L	

SPM- / S P Mandale AAS- A A Shaikh APL- /A P Lad AKC- A K Chvan PPS- P P Shinde MSK- M S Kakamare
 # M-M / Counselor Int. Mentee -Mentor or Counselor Interaction *-Extra (T)-Tutorial # - Alternate LVH-Library Visit Hour @- IITST-IIT Spoken Tutorial

Sr. No.	Course Code	Name of the Course	Sr. No.	Course Code	Name of the Course	Sr. No.	Course Code	Name of the Course
1	BS201	Engineering Mathematics-II	4	HM204	Communication Skills	7	BS207L	Engineering Physics Laboratory
2	BS202	Engineering Physics	5	ES205	Energy and Environment Engineering	8	ES208L	Engineering Graphics Laboratory
3	ES203	Engineering Graphics	6	ES206	Basic Civil and Mechanical Engineering	9	HM209L	Communication Skills Lab
						10	ES210S	Seminar

(Dr. Sanjay L. Patil)
Time-Table Coordinator
 (F. Y. B. Tech.)

(Dr. Anushka A. Patil)
HOD
 (F. Y. B. Tech.)

(Dr. K. K. Pandeyaji)
Academic Dean

(Dr. B. S. Patil)
I/C Principal



Dr. Vasanttraodada Patil Shetkari Shikshan Mandal's

Padmabhooshan Vasanttraodada Patil Institute of Technology, Sangli
FIRST YEAR ENGINEERING DEPARTMENT (F. Y. B. Tech)
TIMETABLE 2023-24 SEM-II

With Effect
From
01/02/2024

Class: FE-VII		Branch: ECS + CSE (AIDS)			PHYSICS Group		CL-05/06/07
Sr. No.	TIME IN HRS	MONDAY	TUESDAY	WEDNESDAY	THURSDAY	FRIDAY	SATURDAY
1	10:00 TO 11:00	G1- ES208L G2- ES210S G3- BS207L	BS202- GGC (CL07)	G1- HM209L G2-202(T)/201(T) G3- ES208L	BS202- GGC (CL07)	ES203- CDP (CL06)	LVH
2	11:00 TO 12:00		ES205- PVK (CL07)		BS201- RUY (CL07)	BS202- GGC (CL06)	
	12:00 TO 12.45	LONG		RECESS		*-Extra	
3	12.45 TO 13:45	ES203- CDP (CL06)	G1-202(T)/201(T) G2- ES208L G3- ES210S	ES205- PVK (CL07)	G1- ES208L G2- HM209L G3-202(T)/201(T)	G1- ES210S G2- BS207L G3- ES208L	
4	13:45 TO 14:45	HM204- AKC (CL06)		BS201- RUY (CL07)			
	14:45 TO 15:00	SHORT		RECESS			
5	15:00 TO 16:00	*ES203- CDP (CL05)	ES206- CDP (CL06)	# TPO Session / Guest Lec. / M-M / Counselor Int.	G1- BS207L G2- ES208L G3- HM209L	ES206-MSK (CL06)	
6	16:00 TO 17:00	BS201- RUY (CL05)	*BS201- RUY (CL06)			HM204- AKC (CL06)	

RUY-R U Yadav GGC- G G Chinde AKC- A K Chvan CDP- C D Patil PVK-P V Kadam MSK- M S Kakamare
 # M-M / Counselor Int. Mentee -Mentor or Counselor Interaction *-Extra (T)-Tutorial # - Alternate LVH-Library Visit Hour @- IITST-IIT Spoken Tutorial

Sr. No.	Course Code	Name of the Course	Sr. No.	Course Code	Name of the Course	Sr. No.	Course Code	Name of the Course
1	BS201	Engineering Mathematics-II	4	HM204	Communication Skills	7	BS207L	Engineering Physics Laboratory
2	BS202	Engineering Physics	5	ES205	Energy and Environment Engineering	8	ES208L	Engineering Graphics Laboratory
3	ES203	Engineering Graphics	6	ES206	Basic Civil and Mechanical Engineering	9	HM209L	Communication Skills Lab
						10	ES210S	Seminar

(Dr. Sanjay L. Patil)
Time-Table Coordinator
(F. Y. B. Tech.)

(Dr. Anushka A. Patil)
HOD
(F. Y. B. Tech.)

(Dr. K. K. Pandeyaji)
Academic Dean

(Dr. B. S. Patil)
I/C Principal



DEPARTMENTAL ACTIVITY

1) MENTORING ACTIVITY:

Each faculty from respective branch has been **assigned some students for mentoring**. Mentoring Forms (Student Information Form) are maintained by mentor (faculty), which involves **details of students** such as Date of Birth, Blood Group, Mail –ID, Parents information, academic information, his/her involvement in different activities. **At least once in a week interaction with the concerned students is done by respective mentor.**

Through interaction their difficulties **from department, hostel and amenities are known**. The suggestions and difficulties from the interaction are **conveyed to higher authorities** on whom corrective actions are taken. **Personal difficulties** during the interaction are also shared by the students. On which appropriate guidance and help is provided. The mentoring batch allotted is continued till the student completes his/her graduation.

Professional guidance is provided by arranging lectures of eminent personalities from Academic, Industry and Social spheres. Lectures of faculty from other institutions are organized. Mentoring includes **professional guidance, carrier advancement/ course work specific/ lab specific/ total development.**

Note:

- i. Student should collect **Mentoring Forms (Student Information Form)** from Respective **Mentors** and fill this form within **one week from the Commencement of Term and classes.**
- ii. Student should attend Mentoring Lectures as per Time Table Schedule.
- iii. **At least once in a week** interaction with the concerned Mentor is done by respective student.

COUNSELING ACTIVITY

- **Encourage students** to discuss their ideas
- Help to **lower stress and build confidence**
- Increases personal knowledge and organizational awareness
- Gives wisdom, advise, help and encouragement
- Develops an environment that supports constructive criticism
- Experiencing greater self-esteem and motivation to succeed.
- Improving interpersonal relationship such as with teacher and family.
- Receiving assistance in choosing a carrier path.

**Counselor expert: Mrs. Archana Muley (Mobile: 9823787214)**

Internal expert may be Dean, Head of department, Coordinators, Class Teachers, Mentors etc. whereas external expert may be related to medical field. **Counselor** as a mentor has been **assigned for each student**. Counseling sheets are maintained by **Counselor (Mentor)**, **at least once in each week interaction with the concerned class is done by respective counselor.**

CLASS TEACHER

- Receiving assistance with academic endeavors.
- Constructive interaction with a class teacher and participation in collective activities he or she arranges engagement in the field.
- Receiving encouragement to stay in college.
- Receiving assistance in the understanding of subject.
- It supports their advancement in research activity, conference, presentation, publication, pedagogical skill etc.
- Student should collect **Leave Application Form** from Class Teacher
- Defaulter Student should contact with their Class Teacher /Mentor/ Head of First Year Engg. Dept. (Dr. Mrs. A. A. Patil) within 2-3 days after displaying Defaulter List on notice board as well as on college web site.

REMEDIAL LECTURES

Extra lectures are arranged for those students who are either weak in particular subject or failed in previous semester.

Note: 1) Student should **attend Remedial Lectures** as per Time Table Schedule.

2) Time Table Schedule for Remedial Lectures will be display after completion of Mid/ End Term Test.

CO/ EXTRA CURRICULAR ACTIVITIES:

Paper/ PPT Presentation, Nirmitti, Vasantostav and Sports activity benefits the student to participate in extracurricular activities.

Date	Activity Name	Participation level	Outcome

REMARKS: Student should submit Xerox copy of certificates obtained from Co/Extra Curricular Activities to Class Teacher.



ANTI-RAGGING ACTIVITY

ANTI-RAGGING RULES AND REGULATIONS

Ragging is a criminal offense as per act no. 1098 (113/98) WISHI-3, 27-5-99.

What Constitutes Ragging?

Ragging constitutes one or more of any of the following acts:

- Any conduct by any student or students whether by words spoken or written or by an act which has the effect of teasing, treating or handling with rudeness a fresher or any other student.
- Asking any student to do any act which such student will not in the ordinary course do and which has the effect of causing or generating a sense of shame, or torment or embarrassment so as to adversely affect the physique or psyche of such fresher or any other student.
- Any act by a senior student that prevents, disrupts or disturbs the regular academic activity of any other student or a fresher.
- Exploiting the services of a fresher or any other student for completing the academic tasks assigned to an individual or a group of students.
- Any act of financial extortion or forceful expenditure burden put on a fresher or any other student by students.
- Any act of physical abuse including all variants of it: sexual abuse, homosexual assaults, and stripping, forcing obscene and lewd acts, gestures, causing bodily harm or any other danger to health or person.

ADMINISTRATIVE ACTION IN THE EVENT OF RAGGING:

The institution shall punish a student found guilty of ragging after following the procedure and in the manner prescribed here in under

- a) Suspension from attending classes and academic privileges.
- b) Withholding/ withdrawing scholarship/ fellowship and other benefits.
- c) Debarring from appearing in any test/ examination or other evaluation process.
- d) Withholding results.
- e) Debarring from representing the institution in any regional, national or international meet, tournament, youth festival, etc.
- f) Suspension/ expulsion from the hostel.
- g) Cancellation of admission.
- h) Rustication from the institution for period ranging from one to four semesters.
- i) Expulsion from the institution and consequent debarring from admission to any other institution for a specified period.



Library: Late Shri Vishnuanna Patil Technical Library – This spacious Library of the Institute is enriched with more than 59000 Volumes of books with more than 78 Indian, 30 International Journals, 538 online journals and periodicals are subscribed per month. Total nontechnical journal are 09, 1800 digital books and 400 Videos.



Gymkhana and N.S.S.

PVPIT has been keen in providing sufficient time and facilities for sports and gymnasium. The Gymkhana is equipped with the cardio and strength machines. The facilities for outdoor and indoor games like table-tenis, Volleyball, basketball, badminton courts as well as cricket, kho-kho and kabaddi are available. PVPIT shares the athletics track and indoor multipurpose hall with its neighboring sport complex.

The National Service Scheme (NSS) is an Indian government-sponsored flagship for public service program conducted by the Ministry of Youth Affairs and Sports of the Government of India. Popularly known as NSS, it provides opportunity to the student youth of Technical Institution, Graduate and Post Graduate at colleges and University level of India to take part in various government led community service activities and programmes. Under this program we always serve/ help community various social activities arrange by NSS. e.g. Blood Donation and Health Checkup camp, Swachh Bharat Abhiyaan and various social and National activities as per the directions receive from UGC and University..

Hostel



The institute has multi storey hostel building inside the institute campus, which accommodates about 450 boys. There is separate girl's hostel where 225 girls can live comfortably with all amenities. Guest house facility is available for visiting parents. The hostels have all necessary facilities such as water purification plant, water coolers, T.V. Medical First aid center, Water heating plant, News Paper, Reading Room, Indoor games, Canteen, Mess, Laundry, Xerox Center, Public Telephone booth are available inside the campus.

Training and Placement Office (TPO)

Placement @PVPIT Sangli: All students those who are interested for industrial placement, are groomed and prepared to face the interview process. Efforts are made by all means to provide maximum opportunities to each and every student, so that every eligible and interested student get at least one offer



Objectives of Training and Placement

The **Training and Placement (TandP)** cell at PVPIT guide and counsel every students to choose their proper career path, make them eligible and employable. Here we groom future Technocrats as per their interest and make them industry-ready. The objective is to

- ❖ Provide opportunities for industrial placements
- ❖ Motivate them for other placement opportunities *
- ❖ Motivate them to become future entrepreneur
- ❖ Motivate them to opt for Higher Education and research.

At PVPIT students can have their choice of placement other than job in industry. Accordingly we provide with the source of appropriate knowledge and skill which would be resourceful them. Training is given to improve their aptitude and soft skill through expert agencies.

We provide proper platform for *other placements like teaching as a profession, competitive exams, higher education, education abroad, jobs in government or semi government, defence services and research sector. We encourage and empower student to become an entrepreneur and provide them necessary awareness and orientation about it.

Our Recruiters



**Engineering Mathematics – II (4 Credits)****BTBS201****Teaching Scheme**

Lecture: 3 hrs/ week

Tutorial: 1 hr/ week

Evaluation Scheme

Continuous Assessment:- 20 Marks

Mid Term Test:-20 Marks

End Semester Exam:-60 Marks

Course Objectives:

1. To know and discuss the need and use of complex variables to find roots, to separate complex quantities and to establish relation between circular and hyperbolic functions.
2. To understand and solve first and higher order differential equations and apply them as a mathematical modeling in electric and mechanical systems.
3. To determine Fourier series representation of periodic functions over different intervals.
4. To demonstrate the concept of vector differentiation and interpret the physical and geometrical meaning of gradient, divergence & curl in various engineering streams.
5. To know and apply the principles of vector integration to transform line integral to surface integral, surface to volume integral & vice versa using Green's, Stoke's and Gauss divergence theorems.

Course Outcomes:**Students will be able to:**

1. Discuss the need and use of complex variables to find roots, to separate complex quantities and to establish relation between circular and hyperbolic functions.
2. Solve first and higher order differential equations and apply them as a mathematical modeling in electric and mechanical systems.
3. Determine Fourier series representation of periodic functions over different intervals.
4. Demonstrate the concept of vector differentiation and interpret the physical and geometrical meaning of gradient, divergence & curl in various engineering streams.
5. Apply the principles of vector integration to transform line integral to surface integral, surface to volume integral & vice versa using Green's, Stoke's and Gauss divergence theorems.

Unit No.	Details of Content	Hrs
1.	Unit 1: Complex Numbers Definition and geometrical representation ; De-Moivre's theorem (without proof) ; Roots of complex numbers by using De-Moivre's theorem ; Circular functions of complex variable – definition ; Hyperbolic functions ; Relations between circular and hyperbolic functions ; Real and imaginary parts of circular and hyperbolic functions ; Logarithm of Complex quantities.	7
2.	Unit 2: Ordinary Differential Equations of First Order and First Degree and Their Applications Linear equations; Reducible to linear equations (Bernoulli's equation); Exact	7



	differential equations; Equations reducible to exact equations ; Applications to orthogonal trajectories , mechanical systems and electrical systems	
3.	Unit 3: Linear Differential Equations with Constant Coefficients Introductory remarks - complementary function, particular integral ; Rules for finding complementary functions and particular integrals ; Method of variation of parameters ; Cauchy's homogeneous and Legendre's linear equations.	7
4.	Unit 4: Fourier Series Introductory remarks- Euler's formulae ; Conditions for Fourier series expansion - Dirichlet's conditions ; Functions having points of discontinuity ; Change of interval ; Odd and even functions expansions of odd and even periodic functions ; Half-rangeseries	7
5.	Unit 5: Vector Calculus Scalar and vector fields: Gradient , divergence and curl ; Solenoidal and irrotational vector fields; Vector identities (statement without proofs) ; Green's lemma , Gauss' divergence theorem and Stokes'theorem (without proofs)	7

Text Books

- Higher Engineering Mathematics by B. S. Grewal, Khanna Publishers, NewDelhi.
- Advanced Engineering Mathematics by Erwin Kreyszig, John Wiley & Sons, NewYork.
- A Course in Engineering Mathematics (Vol II) by Dr. B. B. Singh, Synergy Knowledge ware,Mumbai.
- A Text Book of Applied Mathematics (Vol I & II) by P. N. Wartikar and J. N. Wartikar, Pune Vidyarthi Griha Prakashan,Pune.
- Higher Engineering Mathematics by H. K. Das and Er. Rajnish Verma, S. Chand & CO. Pvt. Ltd., New Delhi.

Reference Books

- Higher Engineering Mathematics by B. V. Ramana, Tata McGraw-Hill Publications, New Delhi.
- A Text Book of Engineering Mathematics by Peter O' Neil, Thomson Asia Pte Ltd. , Singapore.
- Advanced Engineering Mathematics by C. R. Wylie & L. C. Barrett, Tata Mcgraw-Hill Publishing Company Ltd., NewDelhi.

General Instructions:

- The tutorial classes in Engineering Mathematics-II are to be conducted batchwise. Each class should be divided into three batches for thepurpose.
- The internal assessment of the students for 20 marks will be done based on assignments, surprise tests, quizzes, innovative approach to problem solving and percentage attendance.
- The minimum number of assignments should be eight covering alltopics.



DR. BABASAHEB AMBEDKAR TECHNOLOGICAL UNIVERSITY, LONERE			
Summer Examination – 2023			
Course: B. Tech.	Branch : FE All	Semester : II	
Subject Code & Name: Engineering Mathematics-II (BTBS201)			
Max Marks: 60	Date: 12-07-2023	Duration: 3 Hr.	
Instructions to the Students:			
1. All the questions are compulsory. 2. The level of question/expected answer as per OBE or the Course Outcome (CO) on which the question is based is mentioned in () in front of the question. 3. Use of non-programmable scientific calculators is allowed. 4. Assume suitable data wherever necessary and mention it clearly.			
		(Level/CO)	Marks
Q.1	Solve Any Two of the following.		12
A)	If $\tan(A + iB) = x + iy$ then show that i) $\tan 2A = \frac{2x}{1-x^2-y^2}$ ii) $\tanh 2B = \frac{2y}{1+x^2+y^2}$	Understand (CO1)	6
B)	Show that the roots of $x^5 = 1$ are $1, \alpha, \alpha^2, \alpha^3, \alpha^4$ and hence prove that $(1 - \alpha)(1 - \alpha^2)(1 - \alpha^3)(1 - \alpha^4) = 5$	Understand (CO1)	6
C)	Prove that $\tan \left[i \log \left(\frac{a-ib}{a+ib} \right) \right] = \frac{2ab}{a^2-b^2}$	Understand (CO1)	6
Q.2	Solve Any Two of the following.		12
A)	Solve $\frac{dy}{dx} + x \sin 2y = x^3 \cos^2 y$	Understand (CO2)	6
B)	Solve $y dx - x dy + \log x dx = 0$	Understand (CO2)	6
C)	A constant electromotive force E volts is applied to a circuit containing a constant resistance R ohm in series and a constant inductance L Henries. If the initial current is zero, show that the current builds up to half its theoretical maximum in $\left(\frac{L}{R} \log 2 \right)$ seconds.	Apply (CO2)	6
Q.3	Solve Any Two of the following.		12
A)	Solve $\frac{d^2y}{dx^2} - 2\frac{dy}{dx} + y = e^x + xe^x \cos x$	Understand (CO3)	6
B)	Solve $(D^2 + 2D + 1)y = e^{-x} \log x$ by method of variation of parameters	Understand (CO3)	6
C)	Solve $x^2 \frac{d^2y}{dx^2} - 2x \frac{dy}{dx} + 2y = x^2$	Understand (CO3)	6
Q.4	Solve Any Two of the following.		12
A)	Find the Fourier series of the function $f(x) = x$ in the interval $(0, 2\pi)$.	Understand (CO4)	6
B)	Find the Fourier series of $f(x) = x^2$ in the interval $-\pi < x < \pi$ and hence show that $\frac{\pi^2}{6} = \frac{1}{1^2} + \frac{1}{2^2} + \frac{1}{3^2} + \frac{1}{4^2} + \dots$	Understand (CO4)	6



C)	If $f(x) = \begin{cases} x & , 0 < x < \frac{\pi}{2} \\ \pi - x & , \frac{\pi}{2} < x < \pi \end{cases}$ then find half range Fourier sine series Hence show that $f(x) = \frac{4}{\pi} \left(\sin x + \frac{\sin 3x}{3^2} + \frac{\sin 5x}{5^2} + \dots \right)$	Understand (CO4)	6
Q. 5	Solve Any Two of the following.		12
A)	If $\vec{r} = x\mathbf{i} + y\mathbf{j} + z\mathbf{k}$ and $r = \vec{r} $ then Find $\nabla \cdot \vec{F}$, where $\vec{F} = \left(\frac{x}{r}\right)\mathbf{i} + \left(\frac{y}{r}\right)\mathbf{j} + \left(\frac{z}{r}\right)\mathbf{k}$	Understand (CO5)	6
B)	Verify Green's theorem for $\oint_C ((xy + y^2)dx + x^2dy)$ where C is bounded by $y = x$ and $y = x^2$	Understand (CO5)	6
C)	Verify the Stokes theorem for $\vec{F} = x^2\mathbf{i} + xy\mathbf{j}$ over the square in the plane $z = 0$ bounded by the lines $x = 0, x = a, y = 0$ and $y = a$	Apply (CO5)	6
*** End ***			

**Engineering Physics (4 Credits)****BTBS202****Teaching Scheme**

Lecture: 3hrs/week

Tutorial :1hr/week

Evaluation Scheme

Continuous Assessment: -20Marks

Mid Term Test: -20Marks

End Semester Exam: -60Mark

Course Objectives:

1. To provide a firm grounding in the basic physics principles and concept to resolve many Engineering and technological problems.
2. To understand and study the Physics principles behind the developments of Engineering materials.

Course Outcomes: Students will be able to :

1. Define and explain basic laws, Principles and ideas of physics related to Engineering curriculum.
2. Apply basic principles of oscillation, Ultrasonics, Optics laser, fiber optics, nuclear physics and quantum mechanics to solve engineering problems.
3. Understand crystal structure, magnetic and super conducting properties of materials.

Unit No.	Details of Content	Hrs
1.	Unit I: Oscillation and Ultrasonic's Free oscillation, damped oscillation, Forced oscillation and Resonance, differential wave equation, Ultrasonic waves, production of ultrasonics (Piezoelectric effect, Magnetostriction effect) and its application.	7
2.	Unit II: Optics, Fibre Optics and Laser: Interference of light in thin film, wedge shaped film, Newton's rings, polarization of light, methods for production of polarized light (Reflection, Refraction & Double refraction), Huygen's theory of double refraction, Principle and structure of optical fibre, acceptance angle, acceptance cone, numerical aperture. Principle of laser, Types of laser – Ruby and He-Ne laser and their applications.	7
3.	Unit III: Electron Optics, Nuclear and Quantum Mechanics: G. M counter, Heisenberg's uncertainty principle, Schrödinger's time dependent and time independent wave equations, physical significance of wave function.	7



4.	Unit IV: Crystal Structure, X-rays and Electrodynamics Unit cell, Bravais lattice, cubic system, number of atoms per unit cell, coordination number, atomic radius, packing density, relation between lattice constant and density, lattice planes and Miller indices, X-ray diffraction, Line and Continuous Spectrum of X-ray, Introduction of Maxwell equations (no derivation).	7
5.	Unit V: Magnetic, Superconducting and Semiconducting materials Types of magnetic materials (Diamagnetic, Paramagnetic and Ferromagnetic), B-H curve, Superconductivity, types of superconductors, Meissner effect, properties and applications of superconductor, Band theory of solids, conductivity of semiconductors, Hall effect.	7
Text books <ol style="list-style-type: none">1. Engineering Physics M.N. Avadhanulu and P.G. Kshirsagar. S.Chand and Company LTD.2. Engineering Physics – Dr. L. N. Singh. Synergy Knowledgeware-Mumbai.3. Engineering Physics - R.K. Gaur and S. L. Gupta. DhanpatRai Publications Pvt. Ltd.- New Delhi.4. Fundamental of Physics - Halliday and Resnik. Willey Eastern Limited. Reference books <ol style="list-style-type: none">1. Introduction to Electrodynamics –David R. Griffiths2. Concept of Modern Physics – Arthur Beizer. Tata McGraw-Hill Publishing Company Limited.3. Optics – Ajay Ghatak. Mac Graw Hill Education (India) Pvt. Ltd.4. Science of Engineering Materials- C.M. Srivastava and C. Srinivasan. New Age International Pvt. Ltd.5. Solid State Physics – A.J. Dekker. McMillan India –Limited.6. The Feynman Lectures on Physics Vol. I, II, III.7. Introduction to solid state physics – Charles Kittel. John Willey and Sons		

**Engineering Physics Laboratory
BTBS207L****Practical Scheme**

Lecture: 2 Hrs/ Batch

Evaluation Scheme

Continuous Assessment:- 60 Marks

External Exam:-40 Marks

At least 10 experiments should be performed from the following list.

Sr. No.	Practical
1.	Newton's rings - Determination of radius of curvature of Plano convex lens / wavelength of light
2.	Wedge Shaped film - Determination of thickness of thin wire
3.	Half shade Polarimeter - Determination of specific rotation of optically active material
4.	Laser - Determination of wavelength of He-Ne laser light
5.	Magnetron Tube - Determination of 'e/m' of electron
6.	G.M. Counter - Determination of operating voltage of G.M. tube
7.	Crystal Plane – Study of planes with the help of models related Miller Indices
8.	Hall Effect - Determination of Hall Coefficient
9.	Four Probe Method - Determination of resistivity of semiconductor
10.	Measurement of Band gap energy of Semiconductors
11.	Study of I-V characteristics of P-N junction diode
12.	Experiment on fibre optics
13.	Ultrasonics Interferometer
14.	B-H Curve Experiment
15.	Susceptibility measurement experiment



DR. BABASAHEB AMBEDKAR TECHNOLOGICAL UNIVERSITY, LONERE			
Regular & Supplementary Examination – Winter 2023			
Course: B. Tech.		Branch: All	Semester: I
Subject Code & Name: BTBS102P (Engineering Physics)			
Max Marks: 60		Date: 03-01-24	Duration: 3 Hr.
Instructions to the Students:			
1. All the questions are compulsory.			
2. The level of question/expected answer as per OBE or the Course Outcome (CO) on which the question is based is mentioned in () in front of the question.			
3. Use of non-programmable scientific calculators is allowed.			
4. Assume suitable data wherever necessary and mention it clearly.			
		(Level/CO)	Marks
Q. 1	Solve Any Two of the following.		12
A)	Define free oscillations. Derive an expression for differential equation of free oscillations.	(CO1) (Remember & Understand)	6
B)	Explain the construction, working for production of ultrasonic waves using Magnetostriction method.	(CO1) (Understand)	6
C)	State properties of ultrasonic waves. A quartz crystal having 03 mm thickness is vibrating at resonance. Calculate the fundamental frequency of vibrations for which ultrasonic waves are generated. Given for quartz, Young's Modulus is 7.9×10^{10} N/m ² , Density is 2650 Kg/m ³	(CO1) (Remember & Understand)	6
Q.2	Solve Any Two of the following.		12
A)	Derive an expression for the optical path difference for the reflected rays in a thin film of constant thickness and hence find the conditions for maxima and minima.	(CO2) (Understand)	6
B)	Explain the construction & working of Helium-Neon Laser with neat & labeled diagram.	(CO2) (Understand)	6
C)	Explain the structure of optical fiber with suitable diagram. Refractive index of the core is 1.48 and that of cladding is 1.47 in an optical fiber. Calculate numerical aperture.	(CO2) (Remember & understand)	6
Q. 3	Solve Any Two of the following.		12
A)	With neat diagram, explain the construction & working of Bainbridge mass spectrograph.	(CO3) (Understand)	6
B)	With graph and suitable diagram explain the construction & working of Geiger Muller Counter.	(CO3) (Understand)	6
C)	Derive Schrodinger's time independent wave equation.	(CO3) (Understand)	6
Q.4	Solve the following questions.		12
A)	Calculate Atomic Packing Fraction for SC, BCC and FCC structures.	(CO4) (Understand)	6



B)	Explain Characteristics X-ray spectra. Calculate the wavelength of X-rays when a potential difference of 20 KV is applied between filament and anode.	(CO4) (Understand)	6
Q. 5	Solve Any Two of the following.		12
A)	Explain B-H curve for ferromagnetic materials.	(Remember & Understand)	6
B)	What is Superconductivity? Explain Meissner effect in Superconductors.	(Remember & Understand)	6
C)	What is Hall effect? Derive an expression for Hall Voltage and Hall coefficient.	(Remember & Understand)	6
*** End ***			

**Engineering Graphics (2 Credits)**
BTES203**Teaching Scheme**

Lecture: 2 hrs/ week

Evaluation Scheme

Continuous Assessment:- 20 Marks

Mid Term Test:-20 Marks

End Semester Exam:-60 Marks

Course Objectives:

1. To make use of drawing instruments effectively for drawing and dimensioning.
2. To understand the conventions and methods of engineering drawing.
3. To know the concept of projections of points, lines, planes, solids and section of solids.
4. To understand the Construction isometric and orthographic views of given objects.

Course Outcomes: Students will be able to :

1. Understand basic concepts of engineering drawing and apply the concept of orthographics projection to solve problems.
2. Understand and apply concept of projection to solve problems on projection of point & Line.
3. Understand and apply concept of projection to solve problems on projection of plane, Solid and construct the isometric view. Construct isometric and orthographic views of given objects.

Unit No.	Details of Content	Hrs
1.	Drawing standards and geometrical construction: Drawing standard SP: 46, Type of lines, lettering, dimensioning, scaling conventions. Geometrical construction: Dividing a given straight line into any number of equal parts, bisecting a given angle, drawing a regular polygon given one side, special methods of constructing a pentagon and a hexagon.	4
2.	Orthographic Projections and Projections of Points: Introduction to orthographic projection, drawing of orthographic views of objects from their isometric views. Projection of points lying in four quadrants.	4
3.	Projections of Straight Lines and Planes and their Traces : Projections of lines parallel and perpendicular to one or both planes, projections of lines inclined to one or both planes. Traces of lines. Projections of planes parallel and perpendicular to one or both planes, projection of planes inclined to one or both planes.	4
4.	Projections of Solids Types of solids, projections of solids with axis perpendicular and parallel to HP and VP, solids with axis inclined to one or both the planes. Projections of spheres touching each other.	4



5.	Sectioning of Solids, Isometric Projections Sectioning of solids: Section planes perpendicular to one plane and parallel or inclined to other plane. Isometric projections: Isometric scale, drawing of isometric projections from given orthographic views.	4
-----------	--	----------

Reference/ Text Books

1. N. D. Bhatt, *Engineering Drawing*, Charotar Publishing House, 46th Edition, 2003
2. K. V. Natarajan, *A text book of Engineering Graphic*, Dhanalakshmi Publishers, Chennai, 2006
3. K. Venugopal and V. Prabhu Raja, *Engineering Graphics*, New Age International (P) Ltd, 2008
4. Dhananjay A. Jolhe, *Engineering Drawing with an Introduction to Autocad*, McGraw Hill Education, 2017

**Engineering Graphics Laboratory
BTES208L****Practical Scheme**

Lecture: 4 Hrs/ Batch

Evaluation Scheme

Continuous Assessment:- 60 Marks

External Exam:-40 Marks

List of Practical

Sr. No.	Name of Experiment
1.	Lines, lettering and dimensioning.
2.	Geometrical Constructions.
3.	Orthographic projections.
4.	Projections of points and straight lines
5.	Projections of planes.
6.	Projections of solids.
7.	Section of solids.
8.	Isometric Projections.

DR. BABASAHEB AMBEDKAR TECHNOLOGICAL UNIVERSITY, LONERE

Regular & Supplementary Winter Examination-2023

Course: B. Tech.

Branch : All

Semester : I Sem

Subject Code & Name: BTES103G Engineering Graphics

Max Marks: 60

Date:05-01-24

Duration: 4 Hr.

Instructions to the Students:

1. All the questions are compulsory.
2. The level of question/expected answer as per OBE or the Course Outcome (CO) on which the question is based is mentioned in () in front of the question.
3. Use of non-programmable scientific calculators is allowed.
4. Assume suitable data/ Dimensions wherever necessary and mention it clearly.

Q.1 Solve Any Two of the following.

A) Draw the regular pentagon of side 30 mm

B) Redraw the given figure as per dimensions given.

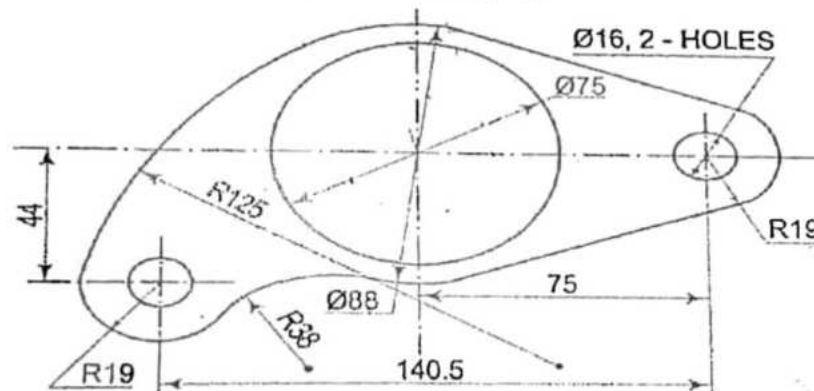

C) Draw the projections of the following points

1. A point C is on HP and 30 mm behind VP, draw the projections of the point. 3M
2. A point B is on VP and 20 mm above HP draw its projections. 3M

Q.2 Solve Any Two of the following.

A) Draw the following views of the object in the direction of arrow as shown below, By using first angle projection method.

a) Front View. 6M

b) Top View. 6M

(Level/ Marks
CO)

12

U 6

A 6

U/A 6

R/A 12

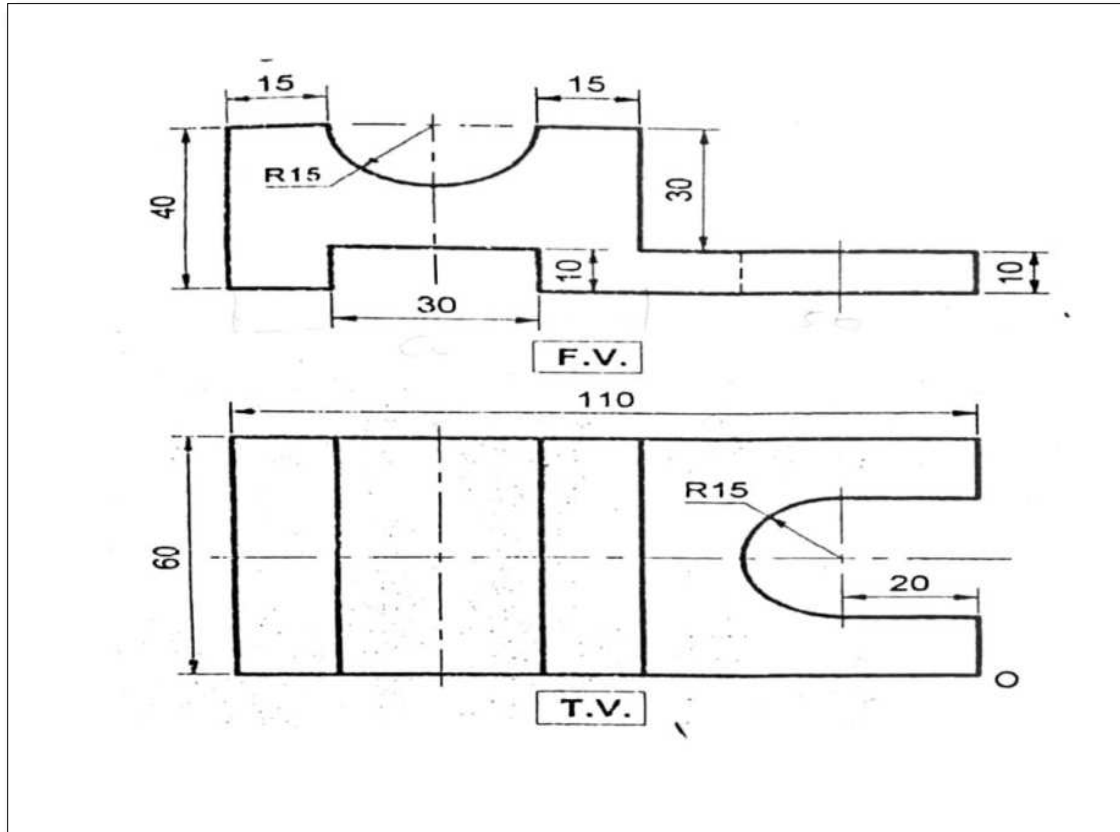

**Communication Skills (2 Credits)****BTHM204****Teaching Scheme**

Lecture: 2 Hrs/ week

Mid Term Test:- 20 Marks

Evaluation Scheme

Continuous Assessment:- 20 Marks

End Semester Exam:- 60 Marks

Course Objectives:

1. To know and apply speaking and writing skills in professional as well as social situations
2. To Overcome Mother Tongue Influence and demonstrate neutral accent while exercising English
3. To know and apply communication skills for Presentations, Group Discussion and interpersonal interactions.
4. To know and apply grammar correctly during Speaking and Writing situations especially in context with Presentations, Public Speaking, Report writing and Business Correspondence

Course Outcomes: Students will be able to:

1. Demonstrate LSRW skills and develop communicative competence in professional presentations.
2. Apply phonetics in spoken English.
3. Make use of grammar correctly with accepted tone and style in technical and business communication.

Unit No.	Details of Content	Hrs
1.	Communication and Communication Processes Introduction to Communication, Forms and functions of Communication, Barriers to Communication and overcoming them, Verbal and Non-verbal Communication Reading: Introduction to Reading, Barriers to Reading, Types of Reading: Skimming, Scanning, Fast Reading, Strategies for Reading, Comprehension. Listening : Importance of Listening, Types of Listening, Barriers to Listening.	4
2.	Verbal and Non-verbal Communication Use of Language in Spoken Communication, Principles and Practice of Group Discussion, Public Speaking (Addressing Small Groups and Making Presentation), Interview Techniques, Appropriate Use of Non-verbal Communication, Presentation Skills, Extempore, Elocution.	4
3.	Study of Sounds in English Introduction to phonetics, Study of Speech Organs, Study of Phonemic Script, Articulation of Different Sounds in English.	2
4.	English Grammar Grammar: Forms of Tenses, Articles, Prepositions, Use of Auxiliaries and Modal Auxiliaries, Synonyms and Antonyms, Common Errors.	5



5.	Writing Skills, Reading Skills and Listening Skills Features of Good Language, Difference between Technical Style and Literary Style, Writing Emails, Formal and Informal English, Technical Reports: Report Writing: Format, Structure and Types Letter Writing: Types, Parts, Layouts, Letters and Applications, Use of Different Expressions and Style, Writing Job Application Letter and Resume.	4
----	---	---

Reference Books:

- 1) Sanjay Kumar, Pushp Lata, *Communication Skills*, Oxford University Press, 2016
- 2) Meenakshi Raman, Sangeeta Sharma, *Communication Skills*, Oxford University Press, 2017
- 3) Teri Kwal Gamble, Michael Gamble, *Communication Works*, Tata McGraw Hill Education, 2010
- 4) Anderson, Kenneth. Joan Maclean and Tossny Lynch. *Study Speaking: A Course in Spoken English for Academic Purposes*. Cambridge: CUP, 2004.
- 5) Aswalthapa, K. *Organisational Behaviour*, Himalayan Publication, Mumbai (1991).
- 6) Atreya N and Guha, *Effective Credit Management*, MMC School of Management, Mumbai (1994).
- 7) Balan, K.R. and Rayudu C.S., *Effective Communication*, Beacon New Delhi (1996).
- 8) Bellare, Nirmala. *Reading Strategies*. Vols. 1 and 2. New Delhi. Oxford University Press, 1998.
- 9) Bhasker, W. W. S and Prabhu, N. S.: *English through Reading*, Vols. 1 and 2. Macmillan, 1975
- 10) Black, Sam. *Practical Public Relations*, E.L.B.S. London (1972).
- 11) Blass, Laurie, Kathy Block and Hannah Friesan. *Creating Meaning*. Oxford: OUP, 2007.
- 12) Bovee Courtland L, and Thrill, John V. *Business Communication*, Today McGraw Hill, New York, Taxman Publication (1989).

Text book:

- 1) Mohd. Ashraf Rizvi, *Communication Skills for Engineers*, Tata McGraw Hill



Communication Skill Lab:

Atleast 10 experiments should be performed from the following list

- 1) How to introduce oneself?
- 2) Introduction to Phonemic symbols
- 3) Articulation of sounds in English with proper manner
- 4) Practice and exercises on articulation of sounds
- 5) Read Pronunciations/transcriptions from the dictionary
- 6) Practice and exercises on pronunciations of words
- 7) Introduction to stress and intonation
- 8) Rapid reading sessions
- 9) Know your friend
- 10) How to introduce yourself
- 11) Extempore
- 12) Group discussion
- 13) Participating in a debate
- 14) Presentation techniques
- 15) Interview techniques

**DR. BABASAHEB AMBEDKAR TECHNOLOGICAL UNIVERSITY, LONERE****Regular & Supplementary Winter Examination-2023**

Course: B. Tech.

Branch: All Branches

Semester: I

Subject Code & Name: (BTHM104) Communication Skills

Max Marks: 60

Date: 08/01/2024

Duration: 3 Hrs.

Instructions to the Students:

1. All the questions are compulsory.
2. The level of question/expected answer as per OBE or the Course Outcome (CO) on which the question is based is mentioned in () in front of the question.
3. Use of non-programmable scientific calculators is allowed.
4. Assume suitable data wherever necessary and mention it clearly.

	(Level/CO)	Marks
Q.1 Solve any TWO of the following:		
A) What are the primary functions of communication?	L1/CO1	6
B) Explain how verbal and non-verbal communication differ in conveying messages.	L2/CO1	6
C) How do strategies for reading contribute to the process of comprehension?	L4/CO1	6
Q.2 Solve any TWO of the following:		
A) Explain the principles that guide an effective group discussion.	L2/CO3	6
B) How would you prepare for a job interview using effective interview techniques? Elaborate.	L3/CO3	6
C) What is the importance of language in spoken communication?	L1/CO1	6
Q.3 Solve any TWO of the following:		
A) Write the spelling for the following transcription	L6/CO2	6
i. /ɪg.zæmɪ'neɪfɪv/		
ii. /tek'nɒlədʒi/		
iii. /'wɪndəʊ/		
iv. /fəʊn/		
v. /'jestədeɪ/		
vi. /'kʌbəd/		
B) What is the primary focus of phonetics in the study of language? Name any three speech organs involved in the production of speech sounds.	L1/CO2	6
C) Write a short notes on: i) Accent and ii) Intonation	L1/CO2	6
Q.4 Solve any TWO of the following:		
A) Fill in the blanks with the appropriate article(s): a, an and the	L1/CO4	6
i. It is _____ best book available in _____ library.		



ii. Ichalakranji is _____ Manchester of _____
Maharashtra.

iii. Ramesh is _____ union leader in _____ Tata Steel.

B) Fill in the blanks with correct preposition.(along, into, along with, since, in, for) L1/CO4 6

i. Leela has been writing _____ morning.

ii. Lakhan lived in India _____ ten years.

iii. _____ Patel, Nehru also addressed the meeting.

iv. He jumps _____ the river.

v. The mobile is _____ the box.

vi. He walked _____ the road.

C) a) Rewrite the following sentences as per suggested in the brackets: L1/CO4 6

i. She _____(go) to her village yesterday. (Simple Past Tense)

ii. I _____(live) here in this village since a long time.(Present
Perfect Continuous Tense)

iii. Neeta _____(work) in the factory everyday.(Simple Present
Tense)

b) Write the antonyms for the following words:

i. Abundance

ii. Arrogant

iii. Timid

Q. 5 Solve any ONE of the following:

A) Apply for the post of Asst. Engineer in TCS, Pune. Attach your CV (Assume
required details) L5/CO4 12

B) i) Draft a complaint letter to the amazon for receiving a wrong product. L5/CO4 6

ii) Write a detailed report on the event organized in your college. (For
Example: SIP, Eye Check-up, Blood Donation Camp, etc.) 6

*** End ***



Energy and Environment Engineering (2 Credits) BTES205		
Teaching Scheme Lecture: 2hrs/week Mid Term Test:-20 Marks	Evaluation Scheme Continuous Assessment:- 20 Marks End Semester Exam:-60 Marks	
Course Objectives: 1. To identify conventional, non-conventional energy sources. 2. To understand the power consuming and power developing devices for effective utilization and power consumption 3. To identify various sources of air, water pollution and its effects. 4. To understand noise, soil, thermal pollution and Identify solid, biomedical and hazardous waste. Course Outcomes: Students will be able to: 1. Identify and aware about Conventional and Renewable energy sources. 2. Know the principle of Energy conservation to implement the energy conservation techniques. 3. Identify and control various sources of air, water and noise pollution and their effects.		
Unit No.	Details of Content	Hrs
1.	Conventional Power Generation: Steam power station, Nuclear power plant – Gas turbine power plant- Hydro power station: Schematic arrangement, advantages and disadvantages, Thermo electric and thermionic generators, Environmental aspects for selecting the sites and locations of power plants.	4
2.	Renewable Power Generation: Solar, Wind, Biogas and Biomass, Ocean Thermal energy conversion (OTEC), Tidal, Fuel cell, Magneto Hydro Dynamics (MHD): Schematic arrangement, advantages and disadvantages.	4
3.	Energy conservation: Scope for energy conservation and its benefits Energy conservation Principle– Maximum energy efficiency, Maximum cost effectiveness, Methods and techniques of energy conservation in ventilation and air conditioners, compressors, pumps, fans and blowers, Energy conservation in electric furnaces, ovens and boilers., lighting techniques.	4
4.	Air Pollution: Environment and Human health - Air pollution: sources- effects- control measures - Particulate emission, air quality standards, and measurement of air pollution.	4
5.	Water Pollution: Water pollution- effects- control measures- Noise pollution –effects and control measures, Disposal of solid wastes, Bio-medical wastes-Thermal pollution – Soil pollution -Nuclear hazard.	4



Reference/ Text Books:

1. A Chakrabarti, M. L Soni, P. V. Gupta, U. S. Bhatnagar, A Text book of Power System Engineering, Dhanpat Rai Publication.
2. Rai. G. D., Non Conventional Energy Sources, Khanna Publishers, Delhi, 2006.
3. Rao S., Parulekar B.B., Energy Technology-Non conventional, Renewable And Conventional, Khanna Publishers, Delhi, 2005.
4. Glynn Henry J., Gary W. Heinke, Environmental Science and Engineering, Pearson Education, Inc, 2004.
5. J. M. Fowler, Energy and the Environment, McGraw-Hill, 2 nd Edition, 1984.
6. Gilbert M. Masters, Introduction to Environmental Engineering and Science, 2nd Edition, Prentice Hall, 2003.



DR. BABASAHEB AMBEDKAR TECHNOLOGICAL UNIVERSITY, LONERE		
Regular & Supplementary Winter Examination – 2023		
Course: B. Tech.	Branch: All B.tech Branches Semester : I	
Subject Code & Name: BTES105 Energy and Environment Engineering		
Max Marks: 60	Date:10-01-24	Duration: 3 Hr.
Instructions to the Students: 1. All the questions are compulsory. 2. The level of question/expected answer as per OBE or the Course Outcome (CO) on which the question is based is mentioned in () in front of the question. 3. Use of non-programmable scientific calculators is allowed. 4. Assume suitable data wherever necessary and mention it clearly.		
	(Level/CO)	Marks
Q. 1	Solve Any Two of the following.	12
A)	Explain in details Nuclear power plant and write the functions of a) moderator b) fuel rod and c) control rod.	Remember/CO1 6
B)	Explain working of open cycle gas turbine power plant with neat sketch. Write advantages and limitations of gas turbine power plant.	Remember/CO1 6
C)	What is thermoelectric generator? Explain construction and working of thermionic power generator.	Remember/CO1 6
Q.2	Solve Any Two of the following.	12
A)	Compare the relative characteristic of HAWT and VAWT. List the major application of wind power.	Understand/CO2 6
B)	Define solar energy with suitable example. Explain working of parabolic collector. Write advantages of photovoltaic system.	Remember/CO2 6
C)	What is the Biomass? Explain construction and working of biogas plant with neat sketch.	Remember/CO2 6
Q. 3	Solve Any Two of the following.	12
A)	What do you mean by energy efficiency? Explain the measures to be taken to reduce the energy conservation in compressor.	Remember/CO3 6
B)	Discuss the scope of energy conservation and principle of energy conservation. How you conserve energy in heat producing equipment with suitable example.	Remember/CO3 6
C)	How will you increase energy efficiency in boiler? Also explain the energy conservation in lightning system.	Remember/CO3 6
Q.4	Solve Any Two of the following.	12



A)	Why TajMahal is turning yellow? Write importance and objectives of National Ambient Air Quality Standards.	Understand/CO4	6
B)	What is a Smog? Explain photochemical smog. Write effect of photochemical smog on human, plant & materials.	Remember/CO4	6
C)	List the control methods of particulate matter. Explain any one with suitable sketch.	Remember/CO4	6
			12
Q. 5	Solve Any Two of the following.		
A)	Define Noise pollution. What are the effect of noise pollution on human, wildlife and properties?	Remember/CO5	6
B)	What are the main causes of river pollution? How can river pollution to be controlled?	Remember/CO5	6
C)	How soil pollution occurs? Write control measures of soil pollution.	Remember/CO5	6
*** End ***			

The grid and the borders of the table will be hidden before final printing.



Basic Civil and Mechanical Engineering (Audit)	
BTES206	
Teaching Scheme	Evaluation Scheme
Lecture: 2 Hrs/ week Audit Course	Continuous Assessment:- 50 Marks
Course Objectives:	
<ol style="list-style-type: none">1. To identify various Civil Engineering materials and choose suitable material among various options.2. To know and apply principles of surveying to solve engineering problem3. To Identify various Civil Engineering structural components and select appropriate structural system among various options4. To Explain and define various properties of basic thermodynamics, materials and manufacturing processes.5. To know and discuss the working principle of various power consuming and power developing devices	
Course Outcomes: Students will be able to:	
<ol style="list-style-type: none">1. To understand principals of surveying in actual practice to prepare plan or map.2. To understand concepts of building planning, building component and uses of building material.3. Define and explain basic terms of thermodynamics, laws of thermodynamics and working of IC Engine & different power plants.4. Define and explain basic terms related to machine, mechanism, engg. materilas and working of machine tools.	

Unit No.	Details of Content	Hrs
	Part I Basic Civil Engineering	
1	Module 1: Introduction to civil engineering Various Branches, role of civil engineer in various construction activities, basic engineering properties and uses of materials: earth, bricks, timber, stones, sand, aggregates, cement, mortar, concrete, steel, bitumen, glass, FRP, composite materials.	4
2	Module 2: Building Components & Building Planning Foundation and superstructure, functions of foundation, types of shallow and deep foundations, suitability in different situation, plinth, walls, lintels, beams, columns, slabs, roofs, staircases, floors, doors, windows, sills, Study of Building plans, ventilation, basics of plumbing and sanitation	4



3	Module3: Surveying Principles of survey, elements of distance and angular measurements, plotting of area, base line and offsets, introduction to Plane table surveying, introduction to leveling, concept of bench marks, reduced level, contours	4
Part II Basic Mechanical Engineering		
1.	Introduction to Mechanical Engineering: Introduction to Laws of Thermodynamics with simple examples pertaining to respective branches, IC Engines: Classification, Applications, Basic terminology, 2 and 4 stroke IC engine working principle, Power Plant: Types of Power plant; Gas power plant, Thermal power plant, Nuclear power plant, Automobiles: Basic definitions and objectives	4
2.	Design Basics, Machine and Mechanisms, Factor of safety, Engineering Materials: types and applications, basics of Fasteners Machining and Machinability, Introduction to Lathe machine, Drilling machine, Milling machine, basics of machining processes such as turning, drilling and milling, Introduction to casting	4



Text Books

- 1) Anurag Kandya, “Elements of Civil Engineering”, Charotar Publishing, Anand
- 2) M. G. Shah, C. M. Kale, and S. Y. Patki, “Building Drawing”, Tata McGraw Hill
- 3) Sushil Kumar, “Building Construction”, Standard Publishers Distributors
- 4) M. S. Palani Gamy, “Basic Civil Engineering”, Tata Mc-Graw Hill Publication
- 5) Kanetkar T. P. and Kulkarni S. V., “Surveying and Levelling”, Vols. I, II and III, Vidyarthi Gruh Prakashan, Pune
- 6) B. C. Punmia, “Surveying”, Vol.- I, Vol.-II, Vol.-III, Laxmi Publications
- 7) G. K. Hiraskar, “Basic Civil Engineering”, Dhanpat Rai Publications
- 8) Gopi Satheesh, “Basic Civil Engineering”, Pearson Education
- 9) P. K. Nag “Engineering Thermodynamics”, Tata McGraw Hill, New Delhi 3rd ed. 2005
- 10) A. Ghosh, A. K. Malik, “Theory of Mechanisms and Machines”, Affiliated East West Press Pvt. Ltd. New Delhi.
- 11) Serope Kalpakaji and Steven R. Schimd “Amanufacturing Engineering and Techology” Addison Wsley Laongman India 6th Edition 2009
- 12) V. B. Bhandari, “Deisgn of Machine Elements”, Tata McGraw Hill Publications, New Delhi.



1) CREDIT SYSTEM AND MODE OF EVALUATION

All the courses in the University and affiliated colleges shall be credit based and the evaluation will be grade based. Credit based grading system is a systematic way of describing an educational programme by attaching credits to its components. The definition of credits may be based on different parameters, such as student workload, learning outcomes and contact hours. It is a student-centric system based on the student workload required to achieve the objectives of a programme. It should facilitate academic recognition of the courses and mobility of the students. Credits assignment is based on the principle that Credits can only be obtained after successful completion of the work required and appropriate assessment of the learning outcomes achieved. Student workload consists of the time required to complete all prescribed learning activities such as attendance at lectures/practical, seminars, projects, etc. Credits are allocated to all the educational components of a study programme and indicate the quantity of work each component requires to achieve its specific objectives. Evaluation is an important component of any teaching-learning process. The University gives emphasis on continuous evaluation with considerable freedom to the teacher in deciding the mode of evaluation of the students. The performance of the student is documented by a grade at the end of the semester. The grading scale ranks the students on a statistical basis. Therefore, statistical data on student performance in his/her class is a prerequisite for applying the grading system.

2. Course Credits

In general, a certain quantum of work measured in terms of credits is laid down as the requirement for a particular degree. The student acquires credits by passing courses every semester, the amount of credits associated with a course being dependent upon the number of hours of instruction per week in that course. There are mainly two types of courses in the University - lecture courses and laboratory courses. Lecture courses consist of lecture (L) and tutorial (T) hours. Laboratory courses consist of practical (P) hours. As per the AICTE norms, the credit (C) for a course is dependent on the number of hours of instruction per week in that course, as given below: (1) 1h/week of lecture (L) or tutorial (T) = 1 credit (2) 2h/week of Practical's (P) = 1 credit (3) Credit (C) for a theory course = No. of hours of lectures per week + No. of hours of tutorials per week = L + T (4) Credits (C) for a Laboratory course = $\frac{1}{2}$ x No. of hours of laboratory course per week Credits will be assigned



to Industrial Training, Seminar, Projects and other mandatory course requirements also and these will be mentioned in the respective syllabi. There may be some non-credit requirements. A student is required to earn credits as mentioned in the syllabus.

3. Evaluation

The weightages of different modes of assessments shall be as under.

In-Semester evaluation				
	Continuous mode (CA)	Mid Semester Exam	End Semester Exam	Components of continuous mode
Theory	20%	20%	60%	Quizzes, class tests (open or closed book but minimum 2 in the semester if only mode of CA), home assignments, group assignments, viva-voce discussions
Practical's	60%	-	40%	Attendance, completion of experiments viva -voce, journal submission, assignments, project, experiments, announced test

4) In-Semester Evaluation

- It is expected that the teacher would conduct at least two formal assessments of the students under the continuous assessment mode in a Semester
- The teacher will announce at the beginning of the respective course the method of conducting the assessments under the continuous mode and the assignment of marks and inform the same to the Director- Academics or Dean in University or Principal/ HoD in affiliated college in the first week of the semester. The same may be also displayed on the University/ College Portal.
- The teacher shall keep the record of the continuous assessment of a class at least for three years and produce it to the Principal of the college or Director-Academics, if needed.
- In-semester performance of all students, both continuous assessment and mid semester examination should be displayed on notice board as well on College / University Portal and sent to the academic office of the University/ College by the teacher before the end-semester examination.
- For the theory courses, there will be one Mid-semester test for



each course to be held as per the schedule fixed in the Academic Calendar of the University/college, preferably in the eighth week of the semester

- e) A candidate who has not appeared for the in-semester continuous tests and/or midterm examination in one or more subjects shall be considered to have not completed the course and will have to re-register for the respective subjects/course in the following year.

5) End-Semester examination

The semester end examination will cover the full syllabus of the course and will be conducted as per the University time table at the end of each semester.

Pass and Fail

(Revised as per the Item 8 of the Minutes of the Academic Council Meeting held on 19th August 2017)

- (a) The candidates who obtain 40% and more marks in a subject head of the end semester examination AND 40% or more of the total marks of a subject head shall be deemed to have passed the respective subject head.
- (b) The candidates who obtain less than 40% of marks in a subject head of the end semester examination and less than 40% the total marks of a subject head shall be deemed to have failed in the respective subject head (Grade FF).

Grades

- (a) The performance of a student shall be documented by a Letter grade. Each letter grade has a Grade point associated with it. The Grades and Grade points shall be assigned to each head of passing and both will be indicated in the mark-list of the semester examination.
- (b) A teacher shall assign absolute marks to all the in-semester tests and the end-semester tests for the respective subject head. The teacher shall collate the marks in the mid semester and continuous mode examinations convert them to prescribed 20% and 20% mark, respectively and submit the same to the office.
- (c) The total marks (continuous assessment + mid-semester + end-semester) of a candidate in a subject head are converted into a letter grade, based on the relative performance of the student in the class taking examination in the subject. The performance of the students who have passed the said subject shall be considered for the allotment of the relative grade on statistical basis.



Letter Grade	Grade Point
EX	10
AA	9.5
AB	9
BB	8.5
BC	8.0
CC	7.5
CD	7
DD	6.5
DE	6.0
EE	5

- (d) The grades to be allotted in the case of students who fail or do not appear at the end semester examination shall be as under.

Letter Grade	Grade Point	Explanation
FF	0	The candidate fails in subject head. The candidate will be allowed to take end-semester repeat or subsequent examinations as per rule
XX	0	(i) The candidate has not kept term for the subject head due to attendance less than requisite 75%. (ii) The in-semester performance of the candidate is very poor. Further see 7.3.5(g) In the above cases, the candidate has to repeat the respective course by paying the fees in the following year
I	0	The candidate has kept term for the subject head, has taken all the internal examinations with satisfactory performance, but has failed to take the end-semester examination due to genuine reasons. The candidate will be allowed to take subsequent examinations as per rule
FR	0	The candidate has exhausted all the permissible chances to clear the end-semester examinations. The candidate has to register for the respective semester again for all the subject heads or will be out of the respective degree course as per the rules
DR	0	(i) The candidate hasn't participated in academic programme. (ii) The candidate has taken a drop for the subject head;- provided he/she intimates the same (i or ii) at least 7 days in advance of



		the commencement of the end-semester examination for the respective year.
--	--	---

- (e) Grades FF and I are place-holders only and do not enter into CGPI/SGPI calculations directly. These grades get converted to one of the regular grades after the end-semester examination.
- (f) A candidate with an FR grade has appeared for maximum number of permissible six end semester examinations and has to re-register for that course by paying the appropriate fees.
- (g) I grade will not be continued beyond the permissible number of six consecutive end semester examinations, irrespective of whether the candidate fails to take any of these exams.
- (h) 'XX' Grade: The grade XX in a course is awarded if – (i) a candidate does not maintain the minimum 75% attendance in the Lecture/Tutorial/Practical classes, (ii) the student has bad or incomplete in-semester records, for example, a candidate missing all internal tests and mid-semester examination, etc., (iii) a candidate indulges in a misconduct/uses unfair means in the examination, assignments, etc., of a nature serious enough to invite disciplinary action in the opinion of the teacher. (Note: Award of the XX grade in the case of g(iii) above shall be done by Disciplinary Action Committee (DAC)).
- (i) The names/ roll numbers of students to be awarded the XX grade should be communicated by the teacher to the Academic office as per academic calendar before the last date of submission of the application for end-semester examination

Awarding the grades

- (1) The grading scale ranks the students on a statistical basis on the basis of the overall performance of the students of a given class in the given subject head. Therefore, statistical data on students' performance is a prerequisite for applying the grading system. While assigning grades in a given subject head, it is essential to know the average marks (AM) obtained by the students who have passed the subject head and the highest marks (HM) obtained in the same subject head.
 - (a) EX Grade shall be awarded to the candidate(s) who scored highest mark (HM) in the concerned subject head provided the marks obtained are 80% or higher in the given subject head.
 - (b) If the average marks (AM) obtained by the students who have passed the subject head is such that $60\% \leq AM < 70\%$, the interval AM shall be awarded grade CC and the other grades shall be decided as follows:
 - (c) AA, AB, BB grades shall be decided between the AM and HM by dividing the range in equal intervals.
 - (d) CC, CD, DD, DE and EE grades shall be decided between the AM and minimum marks required for passing the head (i.e. 40%) by dividing the range in equal intervals.



- (2) If the average marks (AM) obtained by the students who have passed the subject head is $\geq 70\%$, the interval AM shall be awarded grade BB and the other grades shall be decided as follows:
- AA, AB and BB grades shall be decided between the AM and HM by dividing the range in equal intervals.
 - BC, CC, CD, DD, DE and EE grades shall be decided between the AM and minimum marks required for passing the head (i.e. 40%) by dividing the range in equal intervals
- (3) Illustration of award of different grades are explained in the following examples:
- Example 1: HM = 92, AM = 76
Hence, IL = $(76-40)/6 = 6$, IU = $(92-76)/3 = 5.33 \approx 5$
 - Example 2: HM = 84, AM = 62
Hence, IL = $(62-40)/5 = 4.4 \approx 4$, IU = $(84-62)/4 = 5.5 \approx 6$

Marks distribution for different grades

Sr. No.	Letter Grade	Example 1 (HM=92, AM= 76, IL = 6, IU = 5	Example 2 (HM=84, AM= 62, IL = 4, IU = 6
1	EE	40 to 45	40 to 43
2	DE	46 to 51	44 to 45
3	DD	52 to 57	48 to 50
4	CD	58 to 63	52 to 55
5	CC	64 to 69	56 to 62
6	BC	70 to 76	63 to 68
7	BB	77 to 81	69 to 74
8	AB	82 to 86	75 to 80
9	AA	87 to 91	81 to 83
10	EX	92	84

6. Semester Grade Point Average (SGPA) and Cumulative Grade Point Average (CGPA)

(a) Semester Grade Point Average (SGPA)

The performance of a student in a semester is indicated by Semester Grade Point Average (SGPA) which is a weighted average of the grade points obtained in all the courses taken by the student in the semester and scaled to a maximum of 10. (SGPI is to be calculated upto two decimal places). A Semester Grade Point Average (SGPA) will be computed for each semester as follows:



$$SGPA = \frac{\sum_{i=1}^n c_i g_i}{\sum_{i=1}^n c_i}$$

Where

‘n’ is the number of subjects for the semester,

‘ c_i ’ is the number of credits allotted to a particular subject, and

‘ g_i ’ is the grade-points awarded to the student for the subject based on his performance as per the above table.

SGPA will be rounded off to the second place of decimal and recorded as such.

(b) Cumulative Grade Point Average (CGPA):

An up to date assessment of the overall performance of a student from the time he entered the Institute is obtained by calculating Cumulative Grade Point Average (CGPA) of a student. The CGPA is weighted average of the grade points obtained in all the courses registered by the student since s/he entered the Institute. CGPA is also calculated at the end of every semester (up to two decimal places). Starting from the first semester at the end of each semester (S), a Cumulative Grade Point Average (CGPA) will be computed as follows:

$$CGPA = \frac{\sum_{i=1}^m c_i g_i}{\sum_{i=1}^m c_i}$$

Where,

‘m’ is the total number of subjects from the first semester onwards up to and including the semester S

‘ c_i ’ is the number of credits allotted to a particular subject, and

‘ g_i ’ is the grade-points awarded to the student for the subject based on his/ her performance as per the above table.

CGPA will be rounded off to the second place of decimal and recorded as such.

(c) The CGPA, SGPA and the grades obtained in all the subjects in a semester will be communicated to every student at the end of every semester/ beginning of the next semester.

(d) When a student gets the grade ‘FF’, or ‘I’ in any subject head during a semester, the SGPA and CGPA from that semester onwards will be tentatively calculated, taking only ‘zero’ grade point for each such ‘FF’ or ‘I’ grade. When the ‘FF’ grade(s) has/ have been substituted by better grades after the repeat examination or subsequent semester examination, the SGPA and CGPA will be recomputed and recorded.

7. Supplementary End-Semester Examination

(Revised as per the item 7 of Minutes of the Academic Council meeting held on 19th August 2017)



- (1) For those candidates who fail in a subject head or are eligible for appearing at the repeat examination, A Supplementary End-Semester Examination of odd semester will be conducted before the regular End semester examination of the even semester.
- (2) A Supplementary End-Semester Examination of even semester will be conducted before the regular End semester examination of the odd semester.
- (3) The marks obtained by candidates in the in-semester examinations (continuous assessment and mid-term examination) will be carried forward in such cases.
- (4) Grading the performance in the Supplementary Examination: The grades will be assigned as per 3.5 and 3.6 above
- (5) Revaluation of end-semester and Supplementary examination: Candidate's performance in these examinations will be announced on web portal of the University and after one month of such announcement the grade statements will be sent to the concerned Department for distribution to the students. Those who want to get the photocopy of their answer books are required to pay the requisite fee. Revaluation of these examinations shall be allowed. Those who would like to have the revaluation of their answer books are required to pay a requisite fee.
- (6) Remedial examination the candidate will have an option of appearing for an Online Remedial Examination, after the declaration of each End-semester examination results, to pass the subject head where he/she has failed in regular end-semester examination of the semester. The candidate will get only EE grade if he clears the remedial examination and can continue with the next semester. However, for improving his grade in the same subject head, the candidate will have an option of appearing in the 'same' subject in the Supplementary Examination before the regular end-Semester examination.

8. Passing of a Semester Examination

A candidate shall be declared as 'PASSED' any semester examination if he/she has

- (a) Cleared all heads of passing by securing grades EE or higher in all the heads;
- (b) Passed all the heads of passing such as project, seminar, training, etc as per the rules;
- (c) Satisfactorily completed all the mandatory requirements of the course;
- (d) paid all the University/college dues;
- (e) No case of indiscipline pending against him/her.

9. Eligibility for the Award of a Degree

A candidate shall be declared eligible for the award of a degree, if he/ she has cleared all the semester examinations as given in (6) above.



10. Award of Degree of Honours

Major Degree

The concept of Major and Minors at B.Tech level is introduced, to enhance learning skills of students, acquisition of additional knowledge in domains other than the discipline being pursued by the student, to make the students better employable with additional knowledge and encourage students to pursue cross-discipline research.

A. Eligibility Criteria for Majors

- i. The Student should have Minimum CGPA of 7.5 up to 4th Semester
- ii. Student willing to opt for majors has to register at the beginning of 5th Semester
- iii. The Student has to complete 5 additional advanced courses from the same discipline specified in the curriculum. These five courses should be of 4 credits each amounting to 20 credits. The students should complete these credits before the end of last semester.
- iv. Student may opt for the courses from NPTEL/ SWAYAM platform. (if the credits of NPTEL/ SWAYAM courses do not match with the existing subject proper scaling will be done).

Student complying with these criteria will be awarded B. Tech (Honours) Degree.

B. Eligibility Criteria for Minors

- i. The Student should have Minimum CGPA of 7.5 up to 4th Semester
- ii. Student willing to opt for minors has to register at the beginning of 5th Semester
- iii. The Student has to complete 5 additional courses from other discipline of their interest, which are specified in the respective discipline. These five courses should be of 4 credits each amounting to 20 credits.
- iv. Student may opt for the courses from NPTEL/ SWAYAM platform. (if the credits of NPTEL/ SWAYAM courses do not match with the existing subject proper scaling will be done)

Student complying with these criteria will be awarded with B. Tech Degree in ----- Engineering with Minor in -----Engineering. (For e.g.: B. Tech in Civil Engineering with Minor in Computer Engineering)